

Crosscut

Newsletter of the Witwatersrand Woodworkers' Association
PO Box 411346, Craighall, 2024

Rebate plane – Stanley #78 – In production since 1885 and still available new.

Secretary: Ken Mutch (Ken.woodman AT gmail.com or 082 806 7693 - replace AT with @ to email)

Editor: Trevor Pope (tpepe AT iafrica.com). All written content and opinions are those of the editor, unless stated. © Copyright reserved.
Go to <http://mysite.mweb.co.za/residents/tpepe/homepage.html> for back issues of *Crosscut*.

Next General Club Meeting on Wednesday, the 9th June 2010 from 18h00 at the WWA clubhouse at REEA. Topic is “Making musical instruments”.

Next Turner’s monthly meeting is on Monday, the 7th June 2010 at 18h00 at the WWA clubhouse at REEA. Demo of turned fruit by Steven Barrett. If you have made any, please bring examples to show. Wood of the Month will be Imbuia.

News

Turners’ Meeting.

Wood of the month – Chris van Heeswijk discussed special figuring in woods and the causes, specifically birds-eyes and burls. He showed pictures of examples in maple and walnut. He also passed around some examples of veneers.

Vuvuzela competition – We were pleased to welcome Jacob Lebeka who is the assistant curator of the Unisa Fine Art Museum, who assisted with the judging. Together with Steven Barrett and Dries Blijnaut, they selected the prizes for the best vuvuzela design. For the loudness competition, each entrant blew his horn from the back of the room, while Herman measured the sound level on his laptop about 5m away at the front. The softest was 88 dBA, and the winner was Ari at 102 dBA. (The measurements were not calibrated and were only relative.)

Please can all the Vuvuzelas for exhibition be brought to the June Turner’s meeting, for collection by Herman to take for display? Please make a label with your name, the title of the piece, the wood used and price, if you wish to sell it. There will be a formal opening of the exhibition of the 8th June at the Unisa gallery.

Lionel Soekoe talked about the techniques and precautions for balancing and dressing of grinding wheels for precision sharpening. He prefers the Norton Global Force wheel, which is a special seeded-gel composite wheel containing high performance microscopic blue ceramic particles. He explained the importance of accuracy and cleanliness in mounting the wheel to avoid run-out and consequent vibration. He also explained some of the safety precautions to take. Lionel has been promoting the Global Force wheel since 2002, and was interested to see that it is only now being promoted by Mick O’Donnell as an alternative to his Ruby wheels on the Toolpost web site (www.toolpost.co.uk) Lionel has compiled a procedure for accurate mounting of grinding wheels to avoid run-out and consequent vibration. This is reproduced at the end of the newsletter, below.

Main Club Meeting - AGM.

At the AGM, Clive Stacey delivered his chairman’s report for the year past before he stood down. Glenn Lopich delivered his treasurer’s report before he too stood down. Nominations were requested for the posts of chairman, treasurer and some ordinary committee members. After much shuffling of feet and gazing at the floor, the posts of chairman and treasurer remained vacant. Ken Mutch proposed that the main club and turner’s committees be combined, as there is some duplication of functions. This was accepted for action. In the absence of some of the Turners’ committee members, it could not be ratified, so it was agreed that it would be discussed further at a first combined committee meeting after the AGM on the 31st May 2010.

At the meeting on the 31st May 2010, the former Main Club committee and the present Turners’ committee met to assign responsibilities for the management of the Club. It was agreed that there was some duplication between the two committees, so the group reviewed the requirements and constraints for the management of the club. A proposal was formulated to be ratified by the next general meeting of both the Turners and Main (General) sections in June.

After considerable discussion the following structure was agreed by all concerned. Effectively, the two committees will be combined. A management committee for the WWA will be put in place comprising:-

Chairman	Herman Potgieter (will also chair the turners group)
Vice-Chairman	Alistair Brande (will chair the general interest group) – General group representative
Secretary	Ken Mutch
Treasurer	Steven Barrett
Member	Chris van Heeswijk – Turners representative
Member	Leanne Cardoso-Lopes – Functions & events
Member	Tom Howden – without portfolio

In addition the following members will manage portfolios without regular attendance at committee meetings.

Crosscut (newsletter) editor	Trevor Pope
Maintenance and Pub control	Costa Carastavakis
Wednesday workshop	Winston Klein
Toymakers	Eddie Marchio
Library	George Simpson

At the June Turners' meeting and the June Main club (General) meeting, the above arrangement will be presented for approval by the members and any concerns will be addressed. The two meetings will be asked to ratify the combined committee, and once ratified, the committee will manage the WWA as before – business as usual.

Wanted:

Small Crates – A request to make one or more small Crates: Inside measurements of Mini Wooden Kist about 130mm x 180mm and 140mm deep with lid and rope handles. See sketch. Those interested should contact Gideon Schutte on 011-519-1839 (w) or 082-496-8455

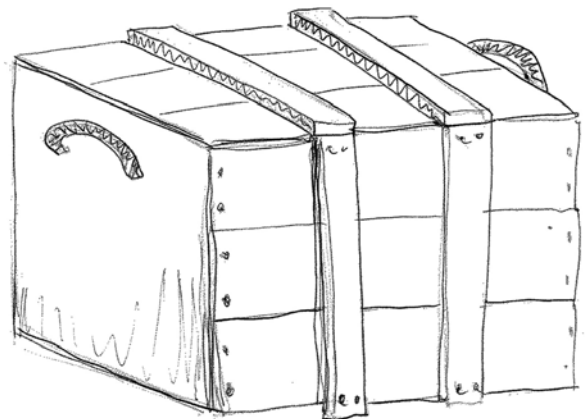

For Sale:

Timber: Approx 7 to 8 cubic meters of timber consisting of Kiaat ($\pm 3m^2$), Iroko, Oak, Honduras Mahogany. Merranti, Parmarfin and Imbuia. Current Retail Value $\pm R80,000-$, will accept R35,000- the lot

Bandsaw. Kity, very good condition, 8" depth of cut, 12" throat. R6000-

Air compressor, Supreme 150 litre, new condition with spray gun, hoses, etc. R5000-

Scroll saw. Ryobi R1,000-

Wood work vices with clamping dog, Record 180mm, all new, never used. (New price $\pm R1750-$ ea) R900- each

Steel Cabinets, various R400- and R800- each

Antique Mahogany Desk R600-

Tool boxes with Spanners and mechanical tools R300- each

AVO Meter, Genuine, very good condition R1,000-

Contact Val Valentin on 011-680-7117 or 083-951-6553

Please Note:

Toymakers. The toymakers meet on the first and third Mondays of every month, at 09h00 till 12h00 at the clubhouse. Contact Eddie Marchio on 011-678-8062 or [renato AT pixie.co.za](mailto:renato@pixie.co.za) for more information.

Wednesday Workshop. The Wednesday evening workshops are on the first and third Wednesdays of every month, from 18h00 till 20h00. Contact Winston Klein on 011-674-1513 for more information.

Lionel's Procedure for ensuring the wheel on a bench grinder is mounted true.

(Contact Lionel Soekoe for more information or practical assistance on this on 011-802-3046 or 072-989-6310)

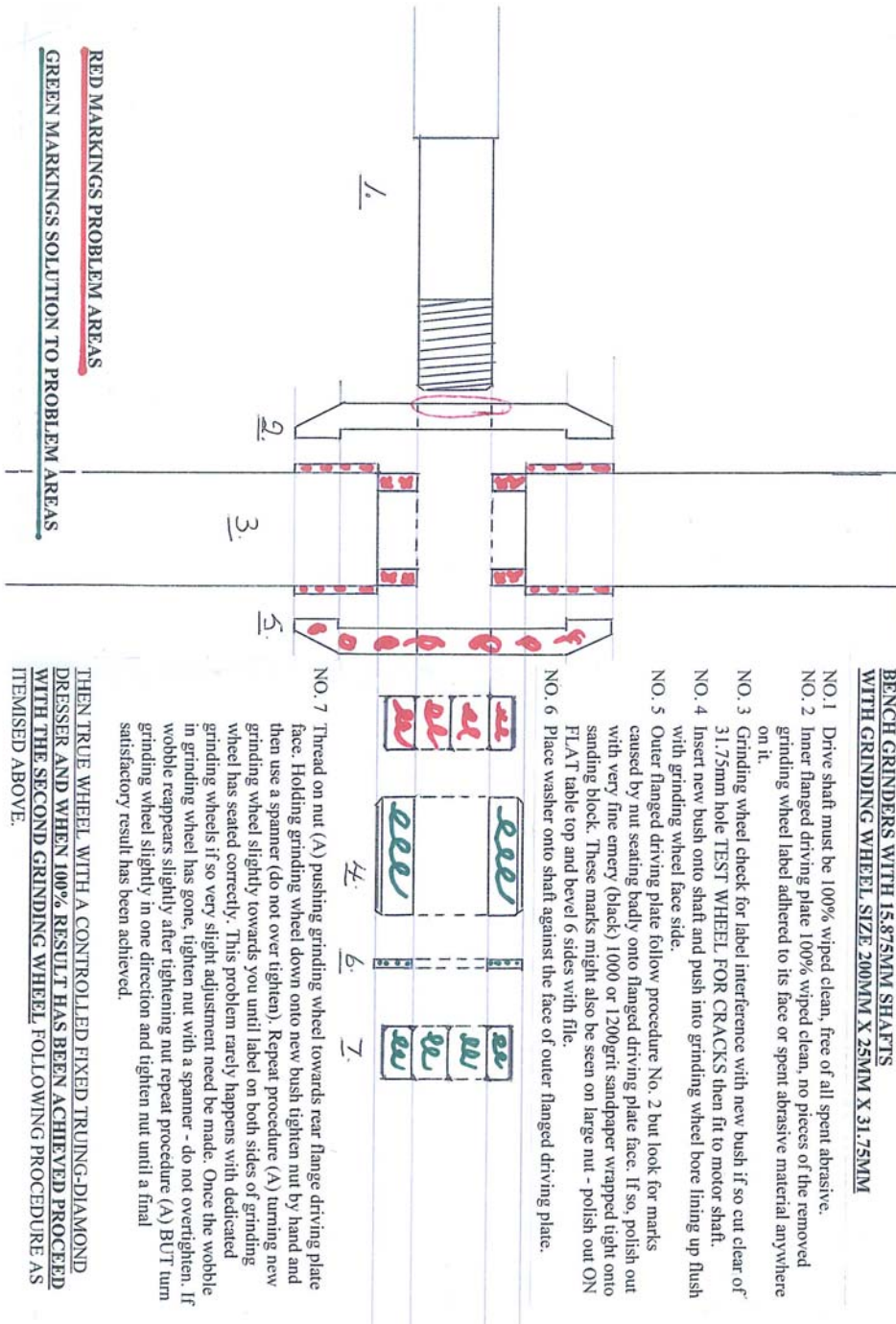

BENCH GRINDERS WITH 15,875MM SHAFTS WITH GRINDING WHEEL SIZE 200MM X 25MM X 31,75MM

- NO. 1 Drive shaft must be 100% wiped clean, free of all spent abrasive.
- NO. 2 Inner flanged driving plate 100% wiped clean, no pieces of the removed grinding wheel label adhered to its face or spent abrasive material anywhere on it.
- NO. 3 Grinding wheel check for label interference with new bush if so cut clear of 31,75mm hole TEST WHEEL FOR CRACKS then fit to motor shaft.
- NO. 4 Insert new bush onto shaft and push into grinding wheel bore lining up flush with grinding wheel face side.
- NO. 5 Outer flanged driving plate follow procedure No. 2 but look for marks caused by nut seating badly onto flanged driving plate face. If so, polish out with very fine emery (black) 1000 or 1200grit sandpaper wrapped tight onto sanding block. These marks might also be seen on large nut - polish out ON FLAT table top and bevel 6 sides with file.
- NO. 6 Place washer onto shaft against the face of outer flanged driving plate.



- NO. 7 Thread on nut (A) pushing grinding wheel towards rear flange driving plate face. Holding grinding wheel down onto new bush tighten nut by hand and then use a spanner (do not over tighten). Repeat procedure (A) turning new grinding wheel slightly towards you until label on both sides of grinding wheel has sealed correctly. This problem rarely happens with dedicated grinding wheels if so very slight adjustment need be made. Once the wobble in grinding wheel has gone, tighten nut with a spanner - do not overtighten. If wobble reappears slightly after tightening nut repeat procedure (A) BUT turn grinding wheel slightly in one direction and tighten nut until a final satisfactory result has been achieved.

THEN TRUE WHEEL WITH A CONTROLLED FIXED TRUING-DIAMOND DRESSER AND WHEN 100% RESULT HAS BEEN ACHIEVED PROCEED WITH THE SECOND GRINDING WHEEL FOLLOWING PROCEDURE AS ITEMISED ABOVE.

RED MARKINGS PROBLEM AREAS

GREEN MARKINGS SOLUTION TO PROBLEM AREAS